

CONTENTS:

Pos	Name:	Art no:	Pcs
1	Sunvisor for Volvo FH/FM 4/5 and FMX	11-0001	1
2	Mirror extension	411	1
3	Installation kit for sunvisor	90-0011	1
4	Carriage bolt M8x30	483	3
5	Washer 8,4x24x2 mm	471	3
6	Locknut M8	461	3
7	Washer 8,4x30x2	485	3



IMPORTANT!

All installations should be done by experienced mechanics/vehicle electricians. In the event of your own modifications or making holes in the product, the warranty expires. Always follow the truck manufacturer's the truck manufacturer's bodywork instructions regarding drilling and wiring in the cab. The same applies to the dimensioning of cabling and the connection of lighting.

TruckStyle Sweden AB does not take responsibility for any damage that occurs in the event of an incorrect installation. The installation instructions describe the installation of sunvisor on a left-hand drive vehicle.

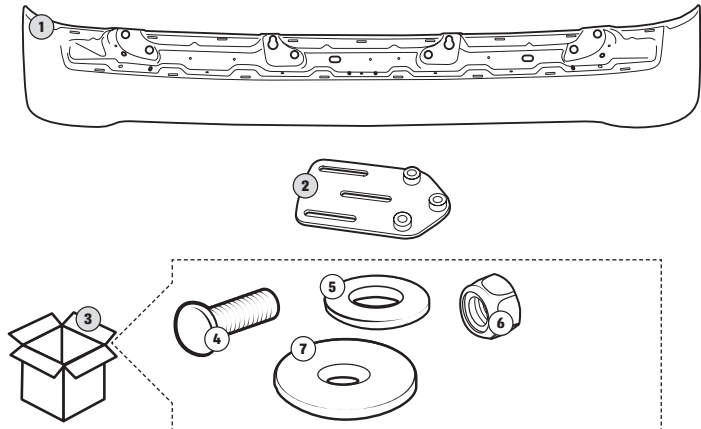

1. Start by removing the upper part (1) of the sunvisor by pushing in the upper part's lockings (2). Remove the outer covers (3).



NOTE! Save the upper part and the insulation behind the cover to be reused for the new sunvisor. Outer covers (3) will not be reused.

1. Upper part
2. Locking
3. Outer cover

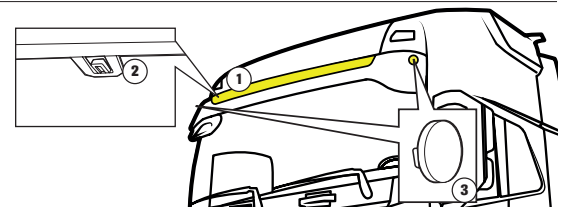

2. Remove the sunvisor from the cab by removing 10 flange screws (1) and washers (2).



NOTE! Save flange screws, washers and underlying seals and spacers. Re-used when installing the new sun visor. Flange screws and flat washers at the two outer attachment points (3) are not reused.

1. Flange screw M8
2. Washer
3. Outer attachment point

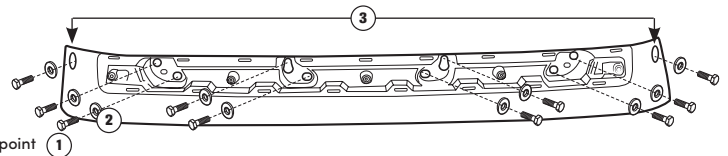

3. Seal the hole on the left exterior of the cabin no longer used attachment point (1). Repeat on the right side of the cabin external no longer used attachment point. On cabs with a high plastic front cover (2) can be ordered from your local Volvo workshop.



IMPORTANT! Seal the outer no longer used holes on the right and left side of the cabin so that water cannot penetrate into the cabin.

1. Cabin's outer attachment point
2. Cover (not included in installation kit)

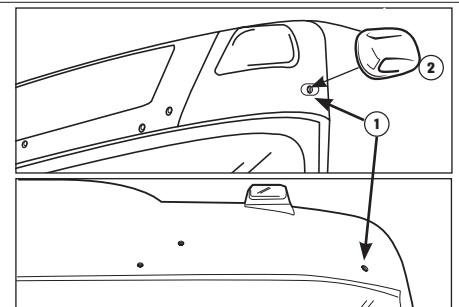

4. Remove the back cover of the front mirror (1), by first pushing in the two upper lockings (2), and then the three lower lockings (3).

Remove the front mirror from the cab by unscrew 3 flange screws (4), flat washers (5), spacers (6) and seals (7).



NOTE! Save spacers (6) and seals (7) to be reused.

1. Front mirror with back cover
2. Upper locking
3. Lower locking
4. Flange screw
5. Washer
6. Spacer
7. Seal

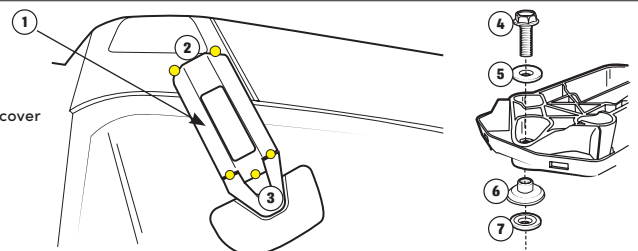

5. Place the mirror extender (1) on the front mirror with 3 carriage bolts (6), spacers (4), seals (5), with flat washers (3) and lock nuts (2).



NOTE! Fit the carriage bolts (6) so that its heads face the windscreen. If the screw connection sits with the nuts against the windshield, they might end up too close to the windshield and can cause damage to the windshield.

1. Mirror extender
2. Locknut M8
3. Washer 8,4x24x2
4. Spacer
5. Seal
6. Carriage bolt M8x30

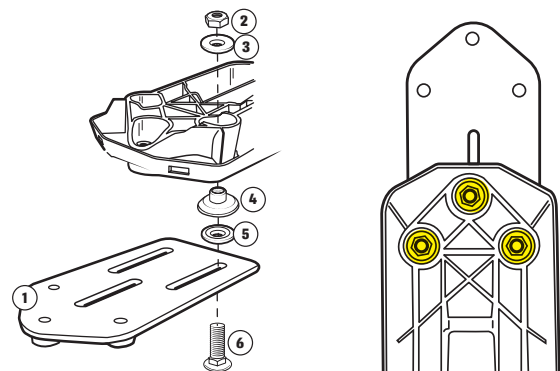

6. Apply a thin layer of sealant around the mounting holes for the front mirror on the cab (yellow marking).

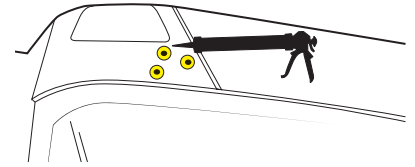

7. Install the front mirror with the extension on the cab with 3 screws (3), spring washers (2) and washers (1). Adjust the mirror and fit the back cover on the front mirror.

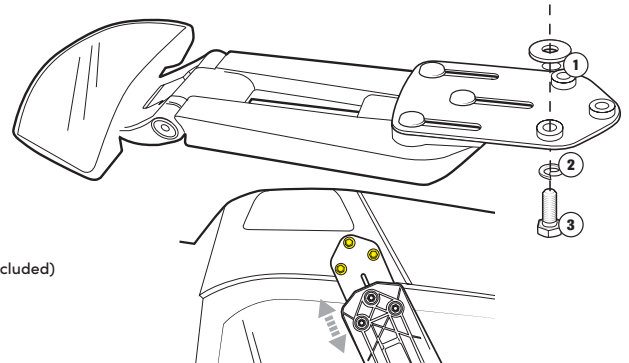

IMPORTANT! In the case of a high cab with a plastic front, any spacer sleeves in the holes for the front mirror must be reused so that you do not tighten directly against the plastic front and crack the plastic.

1. Washer 8,4x30x2 (facing cab)
2. Washer M8 (not included)
3. Hexagon screw M8x40 (not included)

9. Put the original sunvisor's 4 seals (1-4) on the back of the sun visor. Place the original sun visor with 5 spacers (5) large hole and 3 spacers (6) with small holes in the seals.

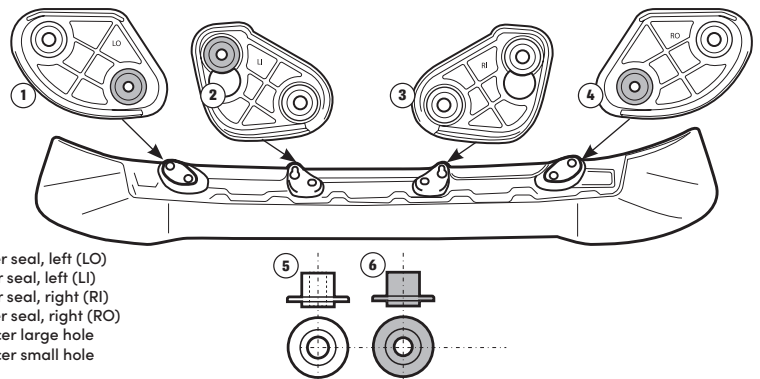

NOTE! On earlier models there may be separate rubber bushings for the spacers, put these in the same place as they were on the original sunvisor.

1. Outer seal, left (LO)
2. Inner seal, left (LI)
3. Inner seal, right (RI)
4. Outer seal, right (RO)
5. Spacer large hole
6. Spacer small hole

10. Place the sunvisor on the cab with the original sunvisor's 8 flange screws (1) and washers (2).



IMPORTANT! Tighten the screw joint by starting with the 4 middle flange screws and lastly tightening the 4 outer ones.

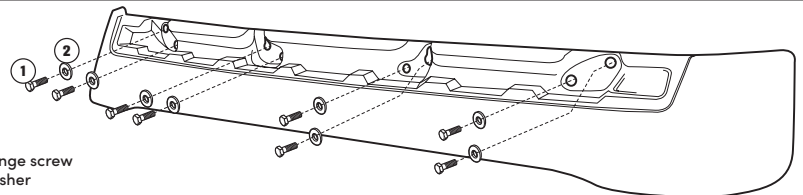

1. Flange screw
2. Washer

11. Put back the original sunvisor's 2 insulations (1)

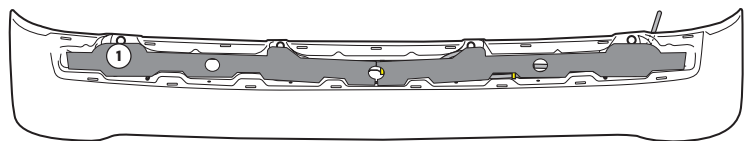

TIP! If the insulation is missing, it can be ordered from your local Volvo workshop.

1. Insulation

12. Put the upper part from the original sunvisor to the new sunvisor (1).

1. Upper part



Use mobile camera to get Swedish Instruction

