



UPP80-3

FUEL ANTI-SIPHON

ULTRA Plus Permanent

Technical specifications

Product details	
Filler neck type	80mm double bayonet
Device Type	Internal Permanent
Locking method	Snap-off screws
Device material	Aluminium alloy
Weight	0.25 kg
Flow speed	150 L/min

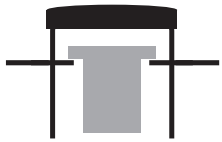

Internal device

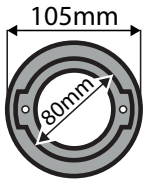

Double bayonet (with flange)



Anti-Spill Valve Available (ASV0003)



Product dimensions (mm)

Use these dimensions to confirm the product will fit your vehicle

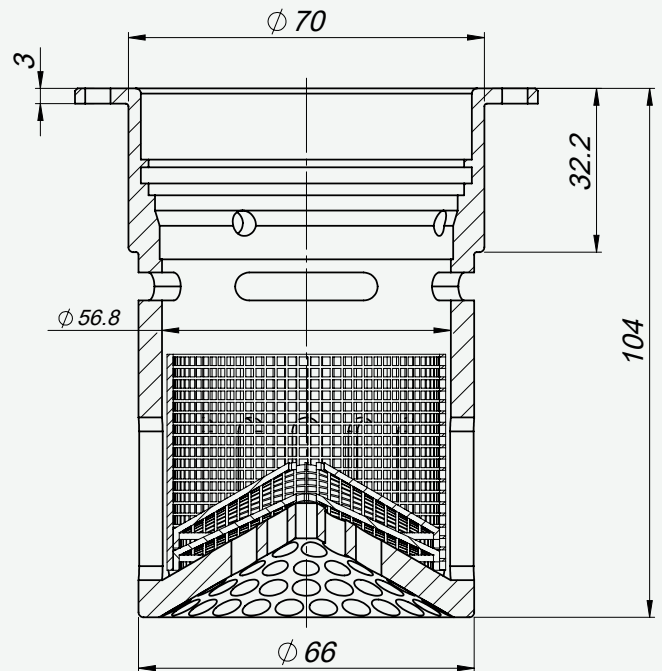
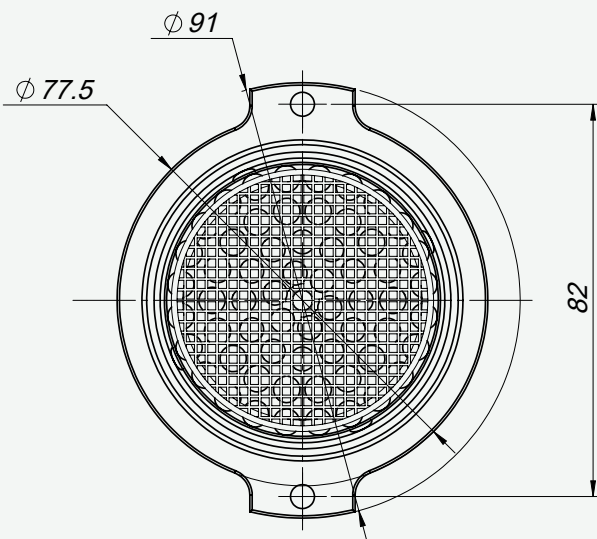

UPP80-3 Vehicle Application List

Truck vehicles fitted

	**Compatible with models that have tank necks with internal flange only	
	Manufacturer	Models
	**DAF	<i>CF65, CF75, CF85, XF Range, XD, XG, XG+</i>
	**Dennis Eagle	<i>Refuse truck - Elite 6</i>
	**FAW	<i>Some models</i>
	**IVECO	<i>Stralis, EuroCargo (metal tank)</i>
	**MAN	<i>All models</i>
	**Mercedes-Benz	<i>All models (excluding Atego plastic tank)</i>
	**Mitsubishi	<i>Canter Fuso some models</i>
**Terberg	<i>Most models</i>	

Other vehicles & machinery

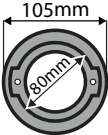
	Manufacturer	Models
	Other	<i>There are more vehicles with the same filler neck, please contact us for more details.</i>